

Building applications

BlueScope Steel Limited products used for building applications are coated with specific corrosion resistant materials which will provide optimum corrosion performance when due regard is paid to material selection, design, storage of materials, correct installation practice and ongoing maintenance procedures.

MATERIAL SELECTION

Perhaps the most important factor in obtaining the optimum performance from BlueScope steel products is to select the appropriate material at the specification stage of the project. Correct selection requires an understanding of the external and internal environment to which the material is to be subjected. Particular attention must be paid to coastal, aggressive industrial situations and intensive farming applications (See [Technical Bulletin TB-1A Steel Roofing Products Selection Guide](#)).

BlueScope Steel market a wide range of both metallic and prepainted steel products (ie COLORBOND® prepainted steel, and ZINCALUME® zinc-aluminium steel) which allow the specifier the opportunity to make a selection based on corrosion resistance, weatherability, colour and gloss retention properties.

Such choices must take into account the relevant aspects of a particular project or fabrication and may deal with practices common to the area of installation. These include dissimilar metals in contact, possible ponding of water, the deposition of contaminants, reflectivity, thermal transmission and aggressive environments.

BlueScope Steel produce coated steel coils from which other manufacturers produce steel building items, such as roofing and rainwater goods. Each manufacturer has published relevant product literature covering design and installation recommendations pertinent to their specific goods. [Technical Bulletin TB-13 General Guide to Good Practice in the Use of Steel Roofing and Walling Products](#) discusses the importance of the typical recommendations found in those publications. The purpose of this bulletin is to further develop some of those recommendations and to introduce some new issues which have been raised in the industry.

DESIGN

The design and structural detail of a project are critical to the service life of the project. A better understanding of the design requirements including such simple things as sheet laps, purlin shape, minimisation of crevices, appropriate fastening techniques and the reduction of areas which are conducive to the build-up of dirt contamination, are examples of specific building industry design issues that if handled correctly, will allow the design life of the structure to be readily attained.

UNWASHED AREAS

It is inevitable that in most building designs there will be certain specific areas which are sheltered from general rain washing. Such areas are evident by the build up of dust and dirt which will lead to an extension of the time of wetness of the material surface in these areas. The time of wetness simply reflects the many variables that control the amount of actual time that any surface remains in contact with sufficient moisture to cause corrosion. The inclusion of corrosion enhancing salts either from marine or industrial pollution will exacerbate the situation leading to a further extension in the time of wetness and enhanced corrosion. The underside of eaves, fascia linings, vertical walls protected by overhanging sections, the top sections of garage doors, the underneath surface of carport roofs are all typical of such unwashed areas. Modern building design which often dictates free floating light weight structures often incorporate unwashed areas. The designer must understand the responsibility inherent in the inclusion of such areas and either minimise their extent or utilise specific BlueScope Steel products which offer improved resistance to unwashed area corrosion.

END LAPPING

Modern roof and wall cladding is manufactured by a continuous roll forming process. Therefore, it is possible for sheet lengths to be manufactured up to the limits of transport regulations, or in some cases, at the building site. These are usually of sufficient length to cover a roof from ridge to gutter without end-lapping the sheets. Should it be necessary, due to handling or other transport considerations, to use shorter sheet lengths, then certain precautions are required to prevent the early deterioration within the lapped joint. Environments where severe condensation arise (e.g reservoir roofing) in combination with inappropriate roof pitch are most likely to develop such problems.

The cut edges of both galvanized and ZINCALUME® steel products enjoy the sacrificial protection provided by the metallic coating. This insures that the extent of the useful life of the product is not detrimentally effected when cut edges are generally exposed. See **Technical Bulletin TB-10** *Cut edge and bend protection of next generation ZINCALUME® aluminium/zinc/magnesium alloy-coated steel and COLORBOND® prepainted steel with Activate® technology.*

However, when the cut edge of the under sheet in an end lap situation is exposed to constantly wet conditions (such as arising from condensation and/or when a corrosive environment is present subjecting the sheet edges to abnormal attack) corrosion of the sheet edge will occur. This environment rapidly depletes the coating in the vicinity of the cut edge and any available metallic coating within close proximity is called upon to protect that cut edge.

The top edge of the under lying sheet is coupled to the underside of the overlapping sheet simply by means of physical contact. The electrolyte which may arise from excessive condensation is sufficient to allow sacrificial corrosion of the top sheet to commence. Eventually the underside metallic coating of the top or lapping sheet is totally consumed and the sheet will perforate along the line of contact (see *Figure 1*).

Figure 1: Cross section of sheet lap.

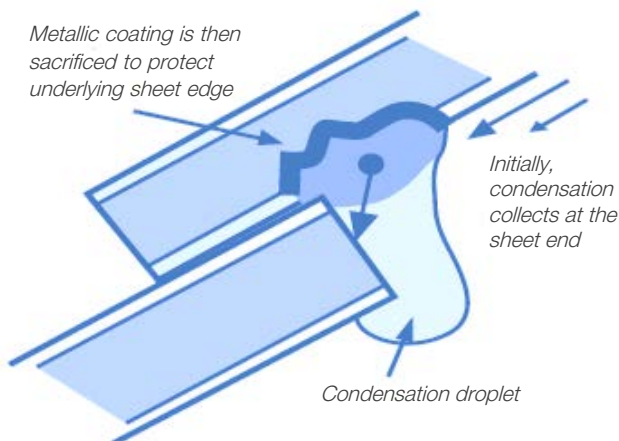

This potential problem can be avoided by ensuring that condensation forming on the underside of the sheets cannot be retained at the point where the cut edge could contact the body of the overlapping sheet. This may be achieved by extruding a generous bead of neutral cure silicone rubber sealant in a position that will encapsulate the top end of the lapped sheet to prevent the retention of water resulting from condensation. A further bead of sealant within the lap, 25mm from the bottom external edge is also necessary to prevent rainwater from being drawn into the lap by capillary action. (*Figure 2*)

Figure 2: Sealant position recommendation.

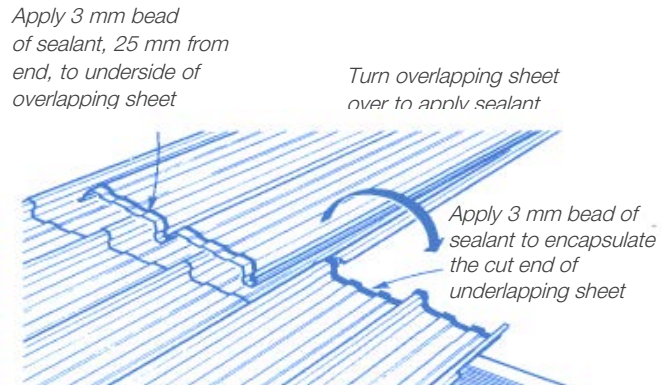

SLIP SHEETS

A common maintenance procedure prior to the introduction of long length roofing was to insert a short (600 mm) length of profiled roofing between corroded end laps in such a position that it would effectively repair the leaks at that point in the roof.

Occasionally this is still done when old roofs are involved, however, it must be realised that ZINCALUME® steel **SHOULD NOT** be used for slip sheets as contact with rusted or bare steel will cause rapid deterioration of the ZINCALUME® steel sheets.

PITCH TRANSITION FLASHING

The addition of extensions to existing dwellings can often lead to incorrect flashing procedures which may direct water and condensation products into roof cavities and lead to consequent damage of interior fixings. In all instances where a change of pitch occurs which may be at an extension or verandah addition to either a sheet or tiled roof residence, the appropriate change of pitch flashing should be chosen to correctly flash the joint, as shown in *Figure 3*.

Under no circumstances should the overlapping sheet be simply fastened firmly down onto the underlying sheet, in the absence of a transition flashing, in an attempt to waterproof the transition joint. Thermally induced stresses will lead to coating removal of the underlying sheet at the point of contact and the onset of rapid corrosion due to the loss of sacrificial metallic coating.

Figure 3: Change of Pitch Flashing.

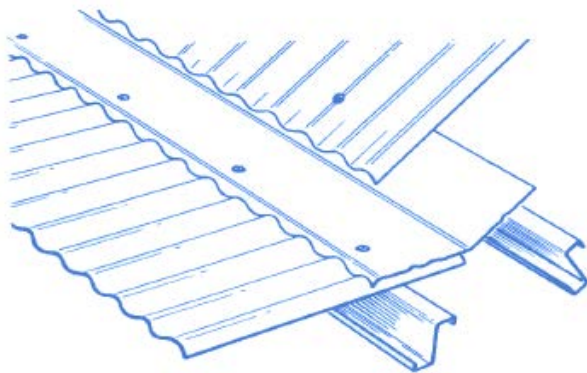

a) Sheet Roof

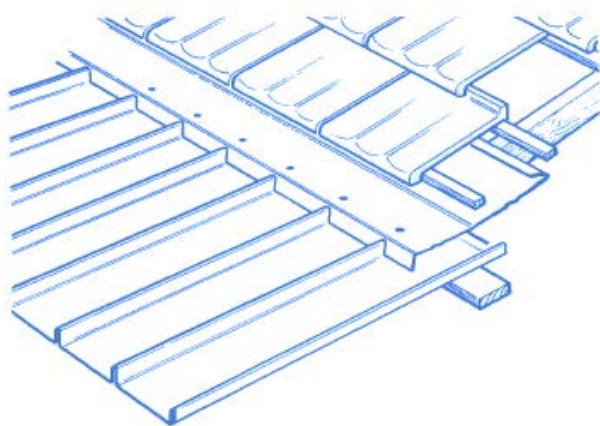

b) Tile Roof

Often dirt is blown into the overlapping roof structure and retained in the upturned decking trays in the absence of correctly fitted transition flashings. The dirt will retain moisture originating from condensation and wind driven rain which quickly leads to perforation of the extension roof decking and penetration of water to the ceiling cavity below.

LOW PITCHED ROOFING

The reduction in pitch, often encountered in simple residential extensions can lead to inappropriately low pitched roofs. If the pitch requirement for the particular profile type is not adequately met, the possibility of water movement through capillary action penetrating the side laps of the roof sheeting, is greatly increased. This will not only lead to water damage of the ceiling structure but to corrosion of the roof sheeting by water retained within the side laps.

EXPANSION JOINTS

Expansion joints must be provided in very long runs of roof sheeting at distances recommended by the cladding manufacturer. Such joints are necessary to overcome longitudinal thermal movement encountered on long roof runs which can result in structural damage to the roof sheeting.

The expansion joint is traditionally formed by raising all the purlins or supports for the roof sheeting on the high side of the chosen lap, which forms a step in the roof run, at a specified height greater than the depth of the profiled sheeting.

Care must be taken when both designing and installing an expansion joint to ensure that the joint is adequately flashed to prevent both wind blown water and dirt entering into the lapped joint. This type of deposition will lead to the formation of a wet poultice on the underlying decking tray and perforation of the underlying sheet.

The design and installation of expansion joints is covered in Australian Standard SAA HB39 - 1997.

If you have any questions regarding this Bulletin, contact BlueScope Steel Direct on 1800 800 789.

To ensure you have the most current Technical Bulletin, please go to steel.com.au



The information and advice contained in this Technical Bulletin ('Bulletin') is of a general nature only and has not been prepared with your specific needs in mind. You should always obtain specialist advice to ensure that the materials, approach and techniques referred to in this Bulletin meet your specific requirements.

BlueScope Steel Limited makes no warranty as to the accuracy, completeness or reliability of any estimates, opinions or other information contained in this Bulletin and to the maximum extent permitted by law, BlueScope Steel Limited disclaims all liability and responsibility for any loss or damage, direct or indirect, which may be suffered by any person acting in reliance on anything contained in or omitted from this Bulletin.

COLORBOND®, ZINCALUME®, Activate® and BlueScope are registered trade marks of BlueScope Steel Limited. This Technical Bulletin applies to all COLORBOND® prepainted steel products and ZINCALUME® steel products.

© 2017 BlueScope Steel Limited ABN 16 000 011 058. BlueScope Steel (AIS) Pty Ltd ABN 19 000 019 625. All rights reserved.

